

4

3

2

1

ZONE	REV.	REVISION DESCRIPTION	ECN NO.	DATE

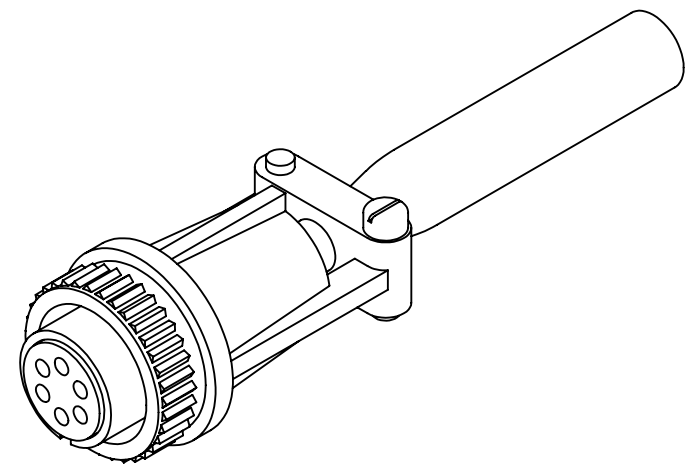
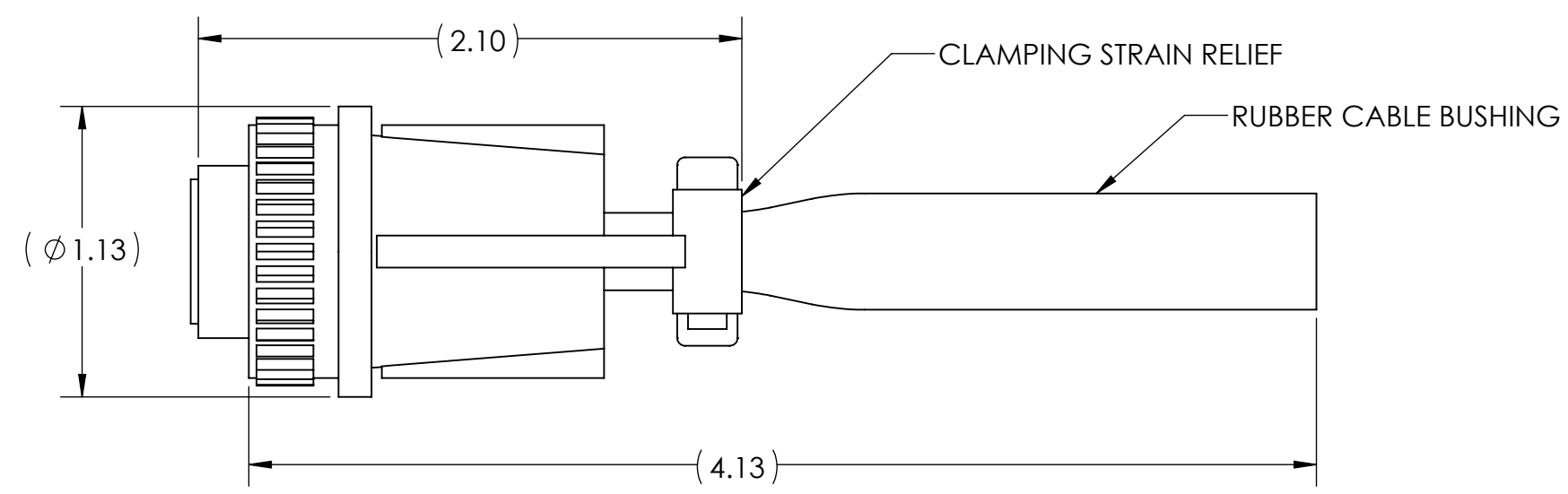
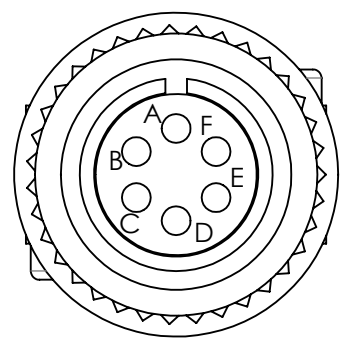

- NOTES (UNLESS OTHERWISE INDICATED):
- ORDER P/N MS3106F14S-6S, MATES WITH MS3102R14S-6P RECEPTACLE
 - INCLUDES CONNECTOR AND RUBBER CABLE BUSHING, P/N MS3420-6 OR EQUIVALENTS
 - PARTS MAY APPEAR DIFFERENT THAN SHOWN HERE DEPENDING ON SUPPLIER

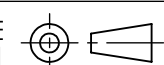
UNCONTROLLED COPY		 BEI SENSORS 1461 LAWRENCE DRIVE THOUSAND OAKS, CA 93120	
FIRST ISSUE DATE: 04/29/19	SENSATA TECHNOLOGIES PROPRIETARY AND CONFIDENTIAL. NEITHER THIS PRINT NOR THE INFORMATION CONTAINED HEREON IS TO BE USED AGAINST THE INTERESTS OF SENSATA TECHNOLOGIES OR AGAINST THE INTERESTS OF ANY OF ITS AFFILIATED COMPANIES OR WHOLLY OWNED SUBSIDIARIES.	TITLE MS3106F14S-6S MATING CONNECTOR	
DRAWN: DRC		INTERPRET DIMENSIONING AND TOLERANCING PER ASME Y14.5-2009. UNLESS OTHERWISE SPECIFIED DIMENSIONS ARE IN INCHES[MILLIMETERS] AND ARE INTENDED AS NOMINAL SEE PRODUCT SPECIFICATIONS FOR MORE DETAILS.	
APPROVED: MFB			
DATE: 04/29/19	DO NOT SCALE DRAWING	THIRD ANGLE PROJECTION	
ECN:		SCALE 1:2	SOLIDWORKS
DATE:		SIZE B	DWG NO. 09918-001
MATERIAL:			REV. .
		SCALE 1:2	SHEET 1 OF 3

4

3

2

1

DEVICE: PROJECT: