

4

3

2

1

ZONE	REV.	REVISION DESCRIPTION	ECN NO.	DATE
	.	.	.	.

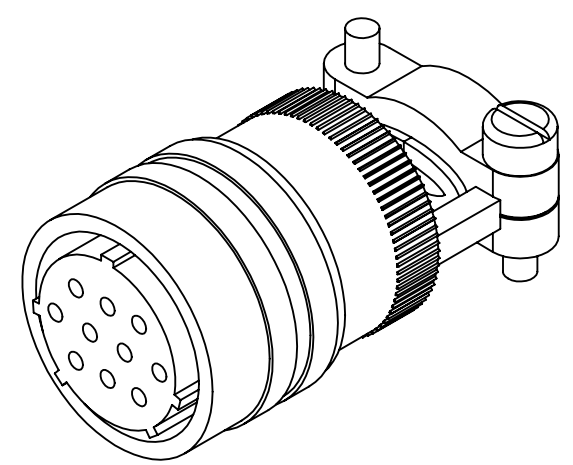
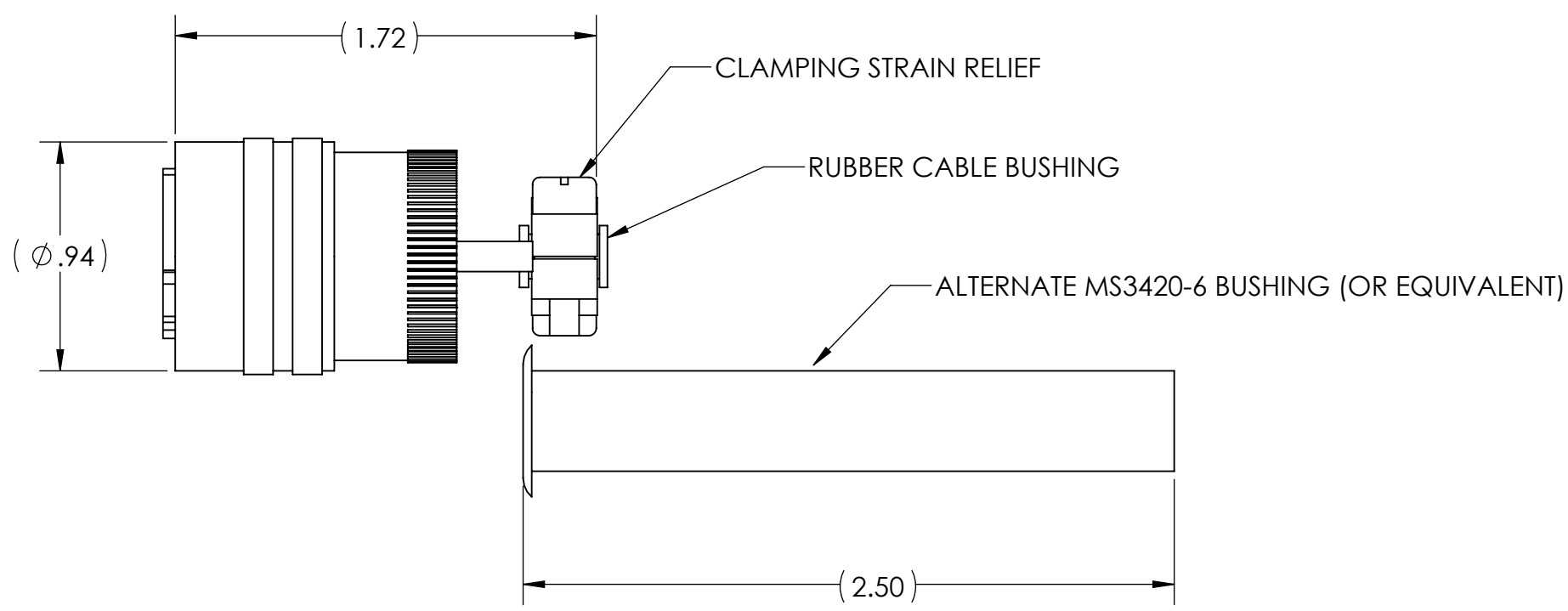
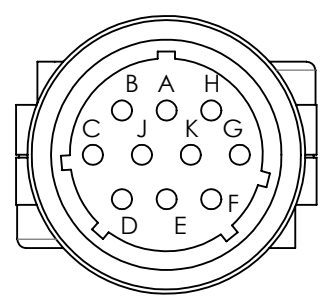

- NOTES (UNLESS OTHERWISE INDICATED)
1. ORDER P/N MS3116F12-10S. MATES WITH MS3112E12-10P RECEPTACLE
  2. INCLUDES CONNECTOR AND TWO TYPES OF RUBBER CABLE BUSHINGS
  3. PARTS MAY APPEAR DIFFERENT THAN SHOWN HERE DEPENDING ON SUPPLIER

UNCONTROLLED COPY

FIRST ISSUE DATE: 05/01/19  
 DRAWN: DRC  
 APPROVED: MFB  
 DATE: 05/01/19  
 ECN:  
 DATE:  
 MATERIAL:

SENSATA TECHNOLOGIES PROPRIETARY AND CONFIDENTIAL. NEITHER THIS PRINT NOR THE INFORMATION CONTAINED HEREON IS TO BE USED AGAINST THE INTERESTS OF SENSATA TECHNOLOGIES OR AGAINST THE INTERESTS OF ANY OF ITS AFFILIATED COMPANIES OR WHOLLY OWNED SUBSIDIARIES.

INTERPRET DIMENSIONING AND TOLERANCING PER ASME Y14.5-2009. UNLESS OTHERWISE SPECIFIED DIMENSIONS ARE IN INCHES[MILLIMETERS] AND ARE INTENDED AS NOMINAL SEE PRODUCT SPECIFICATIONS FOR MORE DETAILS.

DO NOT SCALE DRAWING  
 THIRD ANGLE PROJECTION

BEI SENSORS  
 1461 LAWRENCE DRIVE  
 THOUSAND OAKS, CA 93120

TITLE  
**MS3116F12-10S  
 MATING CONNECTOR**

SIZE	DWG NO.	REV.
<b>B</b>	<b>09918-004</b>	.

SCALE 1:1 SOLIDWORKS SHEET 1 OF 1

4

3

2

1

DEVICE: PROJECT: