

| SENSATA RESONIX™

RGD SERIES REFRIGERANT LEAK SENSOR

Introduction

The Sensata Resonix refrigerant leak detection sensor is a compact embedded module designed to meet demanding OEM requirements and be easily integrated into HVAC & Refrigeration Equipment. Featuring the innovative Speed of Sound technology with high accuracy and fast response times. Superior resistance to overexposure and poisoning, high temperature and humidity resistance, and a lifetime greater than 15 years with no need to calibrate make the Sensata Resonix the ideal, easy to maintain, solution for HVAC&R systems.



Features

- Comply to UL60335-2-40 ed.4
- Works with R32, R454 series and R455 series refrigerants
- LFL range: 0 – 100%
- Built in environmental compensation
- Low power <40mA
- +15 years lifetime
- No field calibration required for the full lifetime

Applications

- Residential and commercial air conditioning
- Heat Pumps
- Refrigeration equipment

SPECIFICATIONS

Mechanical

Materials	Housing: 33% Glass-reinforced PPA Resin Cable: PVC
Dimensions	50 x 80 x 18 mm
Vibrations	10 Hz to 31.5 Hz with 1.0 mm total excursion 31.5 Hz to 150 Hz with 2G acceleration peak
Weight (Approx.)	50 g

Electrical

Output	RS485 Modbus RTU
Supply Voltage	3.3 to 5 VDC
Current Consumption	< 40mA

Environmental / Performance

Target Gases	R32, R454 series and R455 series refrigerants (other refrigerants may be considered upon request.), R1234yf
LFL Range	0 – 100%
Response Time	<10 seconds T25, <30 seconds T90.
Warm Up Time	< 5 seconds
Accuracy	±2.5 % of LFL
Working Temperature	-40°C to +85°C constant, +85°C to +105°C intermittent
Storage Temperature	-40°C to +105°C
Working Humidity	0 to 100% RH (Condensing)
Working Pressure	70 to 120kPa
Protection (EN 60529)	IP54
Fault Detection	Sensor Out of Range
Calibration	Factory calibration, no field calibration required
Compensation	Temperature and Humidity
Lifetime	>15 years
Conformity	UL 60335-2-40 ed.4 Annex LL, UL 60335-2-89 ed.2 Annex 101.DP

DIMENSIONS

Dimensions in mm

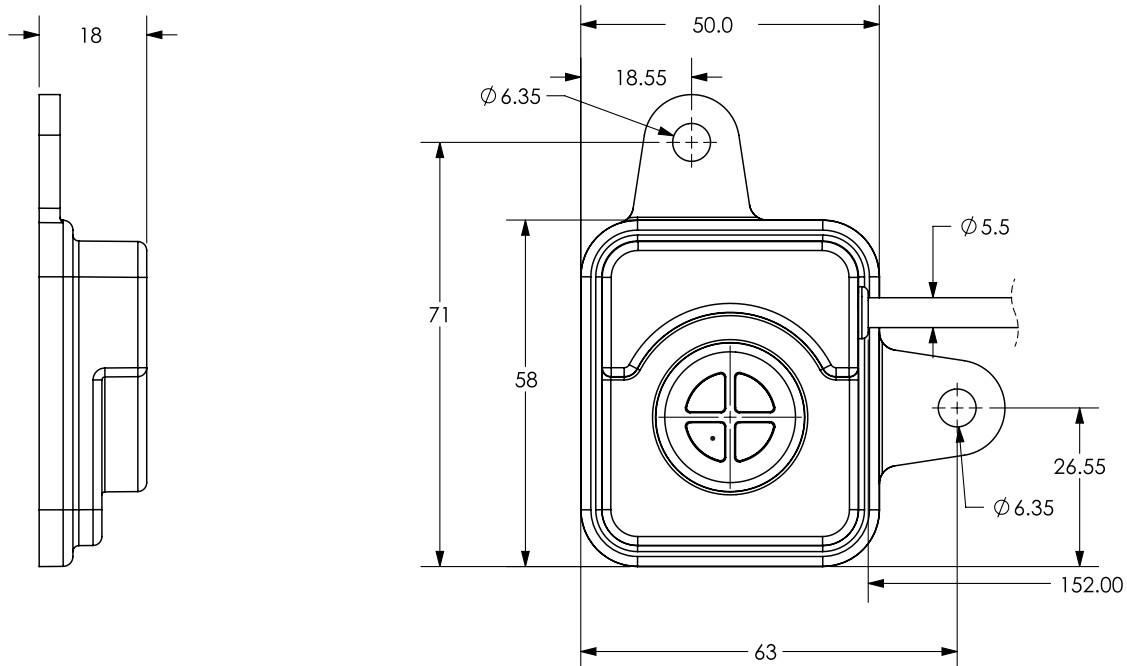

ORDERING OPTIONS

Example : RGD-00ML00

	RGD	-	00	M	L	00
Series						
RGD - Resonix Gas Detection Sensor						
Refrigerant						
00 = R32						
01 = R1234yf						
02 = R454B						
03 = R454C						
04 = R454A						
10 = R455						
Output Type						
M = RS485 MODBUS RTU						
Input Voltage						
L = 3.3 TO 5 VDC						
Customer Specific						
00 = 6 foot unshielded cable, unterminated						
99* = Evaluation Kit (RS 485, 6 foot cable with USB termination, Reader Application.						

* Evaluation kit is intended for evaluation purposes only, and not intended for environmental testing or installation in units used outside of lab settings.

AGENCY APPROVALS & CERTIFICATIONS



Sensata Technologies, Inc. ("Sensata") data sheets are solely intended to assist designers ("Buyers") who are developing systems that incorporate Sensata products (also referred to herein as "components"). Buyer understands and agrees that Buyer remains responsible for using its independent analysis, valuation, and judgment in designing Buyer's systems and products. Sensata data sheets have been created using standard laboratory conditions and engineering practices. Sensata has not conducted any testing other than that specifically described in the published documentation for a particular data sheet. Sensata may make corrections, enhancements, improvements, and other changes to its data sheets or components without notice.

Buyers are authorized to use Sensata data sheets with the Sensata component(s) identified in each particular data sheet. HOWEVER, NO OTHER LICENSE, EXPRESS OR IMPLIED, BY ESTOPPEL OTHERWISE TO ANY OTHER SENSATA INTELLECTUAL PROPERTY RIGHT, AND NO LICENSE TO ANY THIRD PARTY TECHNOLOGY OR INTELLECTUAL PROPERTY RIGHT, IS GRANTED HEREIN. SENSATA DATA SHEETS ARE PROVIDED "AS IS". SENSATA MAKES NO WARRANTIES OR REPRESENTATIONS WITH REGARD TO THE DATA SHEETS OR USE OF THE DATA SHEETS, EXPRESS, IMPLIED, OR STATUTORY, INCLUDING ACCURACY OR COMPLETENESS. SENSATA DISCLAIMS ANY WARRANTY OF TITLE AND ANY IMPLIED WARRANTIES OF MERCHANTABILITY, FITNESS FOR A PARTICULAR PURPOSE, QUIET ENJOYMENT, QUIET POSSESSION, AND NON-INFRINGEMENT OF ANY THIRD PARTY INTELLECTUAL PROPERTY RIGHTS WITH REGARD TO SENSATA DATA SHEETS OR USE THEREOF.

All products are sold subject to Sensata's terms and conditions of sale supplied at www.sensata.com SENSATA ASSUMES NO LIABILITY FOR APPLICATIONS ASSISTANCE OR THE DESIGN OF BUYERS' PRODUCTS. BUYER ACKNOWLEDGES AND AGREES THAT IT IS SOLELY RESPONSIBLE FOR COMPLIANCE WITH ALL LEGAL, REGULATORY, AND SAFETY-RELATED REQUIREMENTS CONCERNING ITS PRODUCTS, AND ANY USE OF SENSATA COMPONENTS IN ITS APPLICATIONS, NOTWITHSTANDING ANY APPLICATIONS-RELATED INFORMATION OR SUPPORT THAT MAY BE PROVIDED BY SENSATA.

Mailing Address: Sensata Technologies, Inc., 529 Pleasant Street, Attleboro, MA 02703, USA

CONTACT US

Americas
 SENSATA TECHNOLOGIES INC.
 529 Pleasant Street,
 Attleboro, MA 02703
 USA
 +1 (800) 350 2727
sensors@sensata.com