

## PARALLEL ABSOLUTE MULTITURN ENCODER – PNP - NPN - PHK5 RANGE

- Blind shaft 14mm, reduction hub available, 15mm option,
- Robustness and excellent resistance to shocks / vibrations,
- High protection level IP65,
- High performances in temperature  $-20^{\circ}\text{C}$  to  $+85^{\circ}\text{C}$ ,
- Parallel output, PNP or NPN,
- Universal electronic circuits from 11 to 30Vdc,
- Protection against short-circuits and inversion of polarity,
- High resolutions available: 8192 (13 bits) per turn,
- Turn counting up to 65 536 (16 bits),
- Reset, select, Latch, Direction functions,
- Option: push-button on the cover for an encoder reset to a value X.

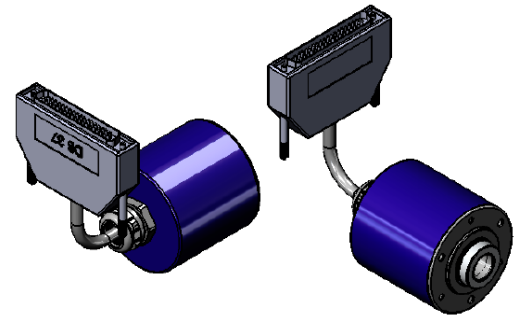

### PHK5 PARALLEL DIMENSIONS

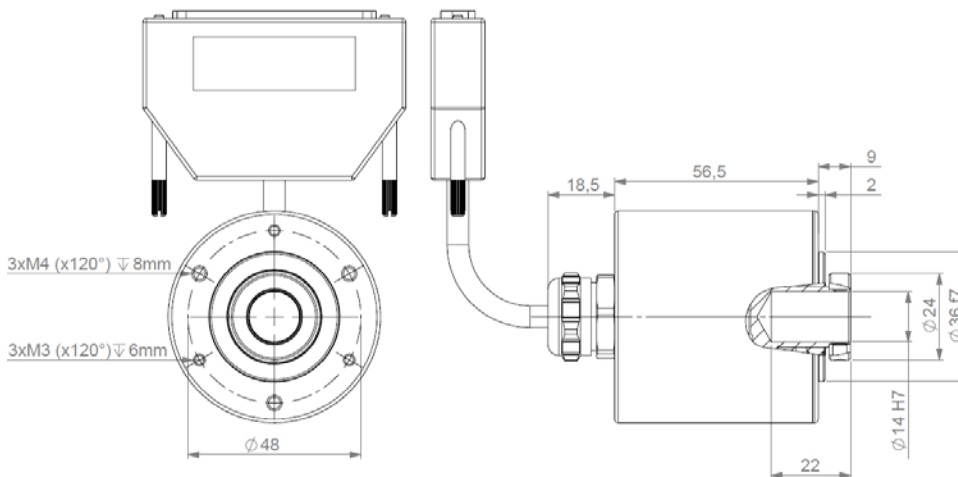

### DAC SYSTEMS

To be ordered separately – several types available:

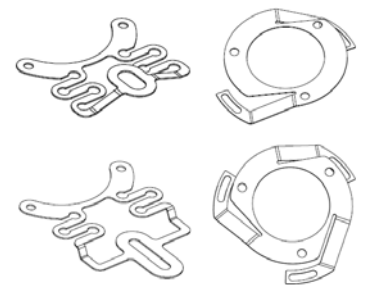

### MECHANICAL CHARACTERISTICS

Material	Cover : treated steel	Vibration (EN60068-2-6)	$\leq 100\text{m.s}^{-2}$ (10 ... 2 000 Hz)
	Body: aluminium	EMC	EN 61000-6-4, EN 61000-6-2
	Shaft : stainless steel	Isolation	100V (1 min)
Bearings	6 803 serie	Weight	0,480 kg
Maximum load	Axial : 20 N	Operating temperature	$-20 \dots +85^{\circ}\text{C}$ (encoder $T^{\circ}$ )
	Radial : 50 N	Storage temperature	$-20 \dots +85^{\circ}\text{C}$
Shaft inertia	$\leq 2,2 \cdot 10^{-6} \text{ kg.m}^2$	Protection(EN 60529)	IP 65
Torque	$\leq 6 \cdot 10^{-3} \text{ N.m}$	Torque (ring pressure screw)	nominal: 1.5N.m, break: 2.0N.m
Permissible max. speed	$6\,000 \text{ min}^{-1}$	Theoretical mechanical lifetime $10^9$ turns ( $F_{axial} / F_{radial}$ )	
Continuous max. speed	$6\,000 \text{ min}^{-1}$	10 N / 25 N	185
		20 N / 50N	24
Shock (EN60068-2-27)	$\leq 500\text{m.s}^{-2}$ (during 6 ms)		

### SCHEMES

#### LATCH input

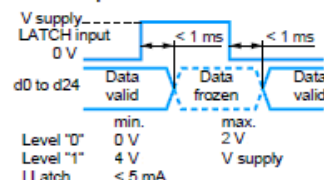

#### DIRECTION input

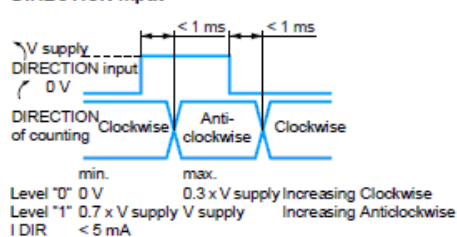

#### SELECT input

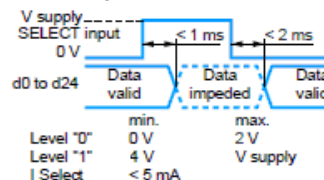

#### Input stage - Reset to zero

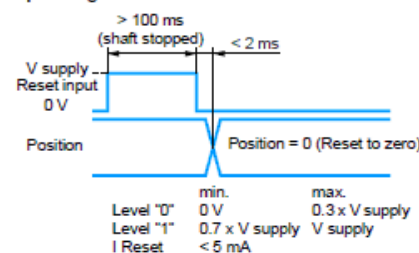

### ELECTRONIC

Power supply	11 – 30Vdc
Introduction	$< 1 \text{ s}$
Cons. without load	$< 100\text{mA}$ (typically 50-60mA at 24Vdc)
Position refresh	$< 200\mu\text{s}$

## PARALLEL ABSOLUTE MULTITURN ENCODER – PNP - NPN - PHK5 RANGE

### ELECTRONIC

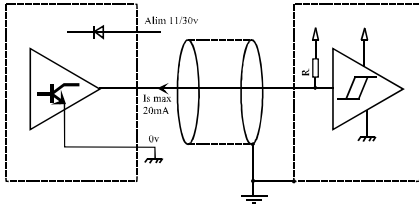

**550 Electronic: OC NPN**  
Power supply: 11 to 30Vdc  
Current consumption (no load) : <100mA  
Max ondulation : 500mV  
Level "0" max : 1,25Vdc  
Protection against polarity inversion

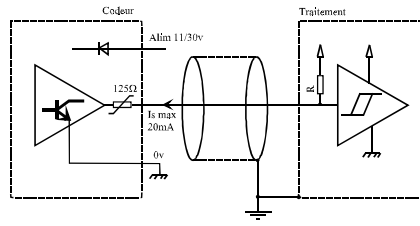

**551 Electronic: OC NPN + CTP**  
Power supply: 11 to 30Vdc  
Current consumption (no load): <100mA  
Max ondulation : 500mV  
Level "0" max : 3,75V at Is max  
Protection against short-circuits  
Protection against polarity inversion

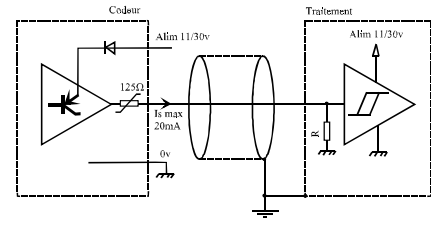

**556 Electronic : OC PNP + CTP**  
Power supply: 11 to 30Vdc  
Current consumption (no load): <100mA  
Max ondulation : 500mV  
Level "1" mini : Vcc- 4,5Vdc at Is max  
Protection against short circuits  
Protection against polarity inversion

### PARALLEL CONNECTION

1	GN green	Output Bit 0
2	YE yellow	Output Bit 1
3	GY grey	Output Bit 2
4	PK pink	Output Bit 3
5	BU blue	Output Bit 4
6	RD red	Output Bit 5
7	BK black	Output Bit 6
8	VT violet	Output Bit 7
9	WH/BN white/brown	Output Bit 8
10	WH/GN white/green	Output Bit 9
11	WH/YE white/yellow	Output Bit 10
12	WH/GY white/grey	Output Bit 11
13	WH/PK white/pink	Output Bit 12
14	WH/BU white/blue	Output Bit 13
15	WH/RD white/red	Output Bit 14
16	WH/BK white/black	Output Bit 15
17	BN/GN brown/green	Output Bit 16
18	BN/YE brown/yellow	Output Bit 17
19	BN/GY brown/grey	Output Bit 18

20	BN/PK brown/pink	Output Bit 19
21	BN/BU brown/blue	Output Bit 20
22	BN/RD brown/red	Output Bit 21
23	BN/BK brown/black	Output Bit 22
24	GN/GY green/grey	Output Bit 23
25	GN/PK green/pink	Output Bit 24
26	GN/BU green/blue	Reserved
27	GN/RD green/red	RESET
28	GN/BK green/black	SELECT
29	YE/GY yellow/grey	LATCH
30	YE/PK yellow/pink	DIRECTION
31	YE/BU yellow/blue	Reserved
32	YE/RD yellow/red	Reserved
33	NC	Reserved
34	YE/BK yellow/black	Reserved
35	RD/BK red/black	Reserved
36	BN brown	11 to 30Vdc
37	WH white	0 Vdc

#### SELECT

Active data output, pin SELECT at 0Vdc  
Non active data output: pin select to +Vcc

#### LATCH

Active data: pin LATCH to 0Vdc  
Data frozen: pin LATCH to +Vcc

DIRECTION, LATCH, RAX and SELECT inputs have to be connected to 0Vdc or +Vcc (LATCH, SELECT and RAX at 0V if not used)

Reserved: Do not connect !

Example of pin assignment for configuration 10x7 bits : data available on pin 1 to 17 - Max: 25 bits (Resolution + Number of turns)

#### DIRECTION

Increasing code clockwise: pin DIRECTION at 0Vdc  
Increasing code counter clockwise: Pin DIRECTION at +Vcc

#### RAX (PRESET to X):

For an electrical RAX (or push-button option) : pin RAX to +Vcc during minimum 100ms.

### ORDERING REFERENCE (Contact the factory for special versions, ex: special flanges, connections, electronics...)

	Shaft Ø	Supply	Output stage	Code	Resolution	Number of turns	Connection	Orientation
PHK5	14 :	5 :	S0 :	G :	13 :	B12	S3	A010 :
	14mm	11 to 30Vdc	NPN OC	Gray	Standard 13 bits	Standard 12 bits	Cable + SUBD37 pinouts output	Axial 1m cable
	Reduction hub available		S1 :	B :	Nota: Available form 0 to 13 bits	Nota: Available form 0 to 16 bits		
	15 :		S6 :			Max: 25 bits (Resolution + Number of turns)		
	15mm option		PNP OC + CTP					
PHK5 _	14 //	5	S1	G //	13	B12 //	S3	A010

Made in France

---

Datasheets provided by Sensata Technologies, Inc., its subsidiaries and/or affiliates (“Sensata”) are solely intended to assist third parties (“Buyers”) who are developing systems that incorporate Sensata products (also referred to herein as “components”). Buyer understands and agrees that Buyer remains responsible for using its independent analysis, valuation, and judgment in designing Buyer’s systems and products. Sensata datasheets have been created using standard laboratory conditions and engineering practices. Sensata has not conducted any testing other than that specifically described in the published documentation for a particular datasheet. Sensata may make corrections, enhancements, improvements, and other changes to its datasheets or components without notice.

Buyers are authorized to use Sensata datasheets with the Sensata component(s) identified in each particular datasheet. HOWEVER, NO OTHER LICENSE, EXPRESS OR IMPLIED, BY ESTOPPEL OR OTHERWISE TO ANY OTHER SENSATA INTELLECTUAL PROPERTY RIGHT, AND NO LICENSE TO ANY THIRD PARTY TECHNOLOGY OR INTELLECTUAL PROPERTY RIGHT, IS GRANTED HEREIN. SENSATA DATASHEETS ARE PROVIDED “AS IS”. SENSATA MAKES NO WARRANTIES OR REPRESENTATIONS WITH REGARD TO THE DATASHEETS OR USE OF THE DATASHEETS, EXPRESS, IMPLIED, OR STATUTORY, INCLUDING ACCURACY OR COMPLETENESS. SENSATA DISCLAIMS ANY WARRANTY OF TITLE AND ANY IMPLIED WARRANTIES OF MERCHANTABILITY, FITNESS FOR A PARTICULAR PURPOSE, QUIET ENJOYMENT, QUIET POSSESSION, AND NON-INFRINGEMENT OF ANY THIRD PARTY INTELLECTUAL PROPERTY RIGHTS WITH REGARD TO SENSATA DATASHEETS OR USE THEREOF.

All products are sold subject to Sensata’s terms and conditions of sale supplied at [www.sensata.com](http://www.sensata.com). SENSATA ASSUMES NO LIABILITY FOR APPLICATIONS ASSISTANCE OR THE DESIGN OF BUYERS’ PRODUCTS. BUYER ACKNOWLEDGES AND AGREES THAT IT IS SOLELY RESPONSIBLE FOR COMPLIANCE WITH ALL LEGAL, REGULATORY, AND SAFETY-RELATED REQUIREMENTS CONCERNING ITS PRODUCTS, AND ANY USE OF SENSATA COMPONENTS IN ITS APPLICATIONS, NOTWITHSTANDING ANY APPLICATIONS-RELATED INFORMATION OR SUPPORT THAT MAY BE PROVIDED BY SENSATA.

Mailing Address: Sensata Technologies, Inc., 529 Pleasant Street, Attleboro, MA 02703, USA

## CONTACT US

### Regional head offices:

#### United States of America

Sensata Technologies

Attleboro, MA

**Phone:** 508-236-3800

**E-mail:** [support@sensata.com](mailto:support@sensata.com)

#### Netherlands

Sensata Technologies Holland B.V.

Hengelo

**Phone:** +31 74 357 8000

**E-mail:** [support@sensata.com](mailto:support@sensata.com)

#### China

Sensata Technologies China Co., Ltd.

Shanghai

**Phone:** +8621 2306 1500

**E-mail:** [support@sensata.com](mailto:support@sensata.com)

Copyright © 2023 Sensata Technologies, Inc.