



## | LANDING GEAR CONTROL LEVER

Pressure Sensor

### Description

Kavlico's Landing Gear Control Lever (LGCL) provides all the necessary elements for control while providing signal indication via a series of internal control switches. Our Landing Gear Control (LGC) unit meets the small envelope, minimum weight, and high reliability demanded by the aerospace industry in part by utilizing our extensive experience in commercial aviation for designing components.

The design of this LGCL contains many features common to Kavlico's overall Landing Gear Control products, whose reliability and durability have been verified through extensive qualification and endurance testing.



Operation of the control handle actuates six independently triggered SPDT (single pole, double throw) switches for signaling position status. A bank of 4-6 switches are triggered when the handle is moved from stowed position to down position or vice versa. The electrical signal initiate the deployment or retraction of the landing gear system.

A spring loaded center mechanism is designed to insure full handle travel to either stow or DN positions, while preventing an accidental stop in any other location in between. An electrically operated down-lock prevents movement of the control handle to the stow position until the aircraft becomes airborne. The down-lock is operated by a continuous-duty rated solenoid. A manual override permits emergency release of the handle lock.

The ergonomic, easy-to-use control knob is designed to meet the FAR Part 25 regulations.

Both the light plate and solenoid receive power through a MIL-DTL-38999 Series III connector. The integrally mounted light plate design is manufactured in accordance with SAE 7788 Type VII. The light plate provides the identification legends for the control handle Up and DN positions and for the down-lock release button.

### Features

- Solenoid Controlled Down Latch
- Redundant Control Switches
- Design Meets FAR Part 25 and RTCA-160
- Emergency Latch Override Button
- Easily Replacable Light Panel



# SPECIFICATIONS

<b>Inadvertency Protection</b>	Continuous duty solenoid down-lock with manual over-ride
<b>Operating Force</b>	2.5 to 5 lbs. (11 to 22N)
<b>Travel Output-Mechanical</b>	40 degrees
<b>Control Knob</b>	Wheel shaped per Far Part 25.781, color 37875
<b>Panel Illumination</b>	MIL-P-7788 or SAE 7788, Type VII (LEO), with 5VDC with variable dimming
<b>Control Switches</b>	Gold Plated contacts, sealed (6 each)
<b>Electrical Receptacle</b>	MIL-DTL-D38999 Connectors/20FD35PN
<b>Color Scheme</b>	Fed-Std 595, color 36118 (lusterless gray)
<b>Markings</b>	Color 37875 (White)
<b>Weight</b>	1.76 lbs. (0.8 Kg.) Max.



# DIMENSIONS

Dimensions in mm [Inch]

## Cut Out Dimensions

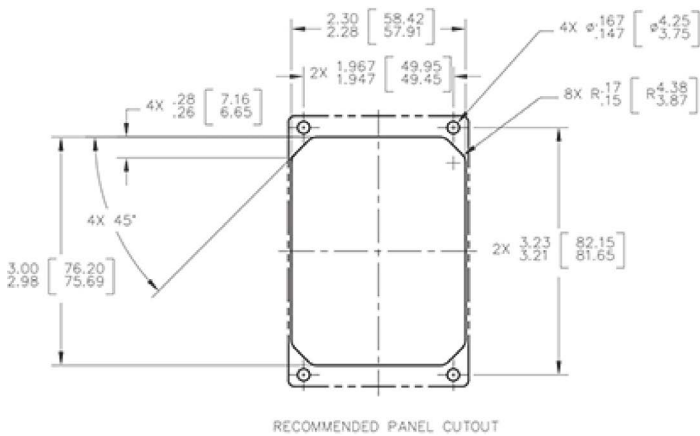

## Electrical Schematic

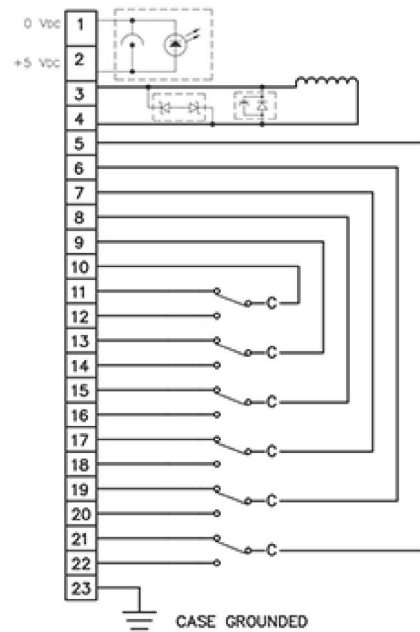

Revised 2/16/18

Sensata Technologies, Inc. ("Sensata") data sheets are solely intended to assist designers ("Buyers") who are developing systems that incorporate Sensata products (also referred to herein as "components"). Buyer understands and agrees that Buyer remains responsible for using its independent analysis, evaluation and judgment in designing Buyer's systems and products. Sensata data sheets have been created using standard laboratory conditions and engineering practices. Sensata has not conducted any testing other than that specifically described in the published documentation for a particular data sheet. Sensata may make corrections, enhancements, improvements and other changes to its data sheets or components without notice.

Buyers are authorized to use Sensata data sheets with the Sensata component(s) identified in each particular data sheet. HOWEVER, NO OTHER LICENSE, EXPRESS OR IMPLIED, BY ESTOPPEL OR OTHERWISE TO ANY OTHER SENSATA INTELLECTUAL PROPERTY RIGHT, AND NO LICENSE TO ANY THIRD PARTY TECHNOLOGY OR INTELLECTUAL PROPERTY RIGHT, IS GRANTED HEREIN. SENSATA DATA SHEETS ARE PROVIDED "AS IS". SENSATA MAKES NO WARRANTIES OR REPRESENTATIONS WITH REGARD TO THE DATA SHEETS OR USE OF THE DATA SHEETS, EXPRESS, IMPLIED OR STATUTORY, INCLUDING ACCURACY OR COMPLETENESS. SENSATA DISCLAIMS ANY WARRANTY OF TITLE AND ANY IMPLIED WARRANTIES OF MERCHANTABILITY, FITNESS FOR A PARTICULAR PURPOSE, QUIET ENJOYMENT, QUIET POSSESSION, AND NON-INFRINGEMENT OF ANY THIRD PARTY INTELLECTUAL PROPERTY RIGHTS WITH REGARD TO SENSATA DATA SHEETS OR USE THEREOF.

All products are sold subject to Sensata's terms and conditions of sale supplied at [www.sensata.com](http://www.sensata.com) SENSATA ASSUMES NO LIABILITY FOR APPLICATIONS ASSISTANCE OR THE DESIGN OF BUYERS' PRODUCTS. BUYER ACKNOWLEDGES AND AGREES THAT IT IS SOLELY RESPONSIBLE FOR COMPLIANCE WITH ALL LEGAL, REGULATORY AND SAFETY-RELATED REQUIREMENTS CONCERNING ITS PRODUCTS, AND ANY USE OF SENSATA COMPONENTS IN ITS APPLICATIONS, NOTWITHSTANDING ANY APPLICATIONS-RELATED INFORMATION OR SUPPORT THAT MAY BE PROVIDED BY SENSATA.

Mailing Address: Sensata Technologies, Inc., 529 Pleasant Street, Attleboro, MA 02703, USA.

Copyright © 2018 Sensata Technologies, Inc.

## CONTACT US

### Americas

+1 (800) 350 2727 – Option 1  
[sales.beisensors@sensata.com](mailto:sales.beisensors@sensata.com)

### Europe, Middle East & Africa

+33 (3) 88 20 8080  
[position-info.eu@sensata.com](mailto:position-info.eu@sensata.com)

### Asia Pacific

[sales.isasia@list.sensata.com](mailto:sales.isasia@list.sensata.com)  
China +86 (21) 2306 1500  
Japan +81 (45) 277 7117  
Korea +82 (31) 601 2004  
India +91 (80) 67920890  
Rest of Asia +886 (2) 27602006  
ext 2808

[www.sensata.com](http://www.sensata.com)